



TRUCKING



AGRICULTURE



CONSTRUCTION



MARINE



OIL & GAS



MINING



Red-L Distributors Ltd.

www.redl.com

1.800.252.9390

Bonnyville 780.826.2333
Bonnyville@redl.com

Edmonton west 780.451.2820
rednorth@redl.com

Fort McMurray 780.791.0404
ftmac@redl.com

Grande Prairie 780.814.6010
gp@redl.com

Nisku 780.437.2630
Sales@redl.com

Spruce Grove 780.962.1147
sprucegrove@redl.com

Calgary 403.720.2872
calgary@redl.com

Edmonton south 780.431.8643
redsouth@redl.com

Fort St. John 778.715.2909
fortstjohn@redl.com

Lloydminster 780.871.0766
Lloydminster@redl.com

Red Deer 403.346.4673
reddeer@redl.com

Whitecourt 780.778.5119
whitecourt@redl.com



BALDWIN

FILTERS

ON-HIGHWAY FILTRATION

DEPENDABILITY FOR THE LONG HAUL
IT'S IN OUR BLOOD



IF IT WAS EASY EVERYONE WOULD BE DOING IT

You face tough challenges every day, but filtration shouldn't be one of them. Baldwin can make your job easier. We have the coverage, quality, service and availability you need. Whether you're an owner-operator or managing an entire fleet, Baldwin has what it takes to be your one-source filter provider and keep your trucks on the road where they belong.

QUALITY

When it comes to protecting your engine, you don't settle for anything but the best. Neither does Baldwin. Every phase of production, from raw material purchase to final inspection, is designed to ensure the highest quality and performance standards.

SERVICE

Getting an honest answer is important to you. Baldwin agrees. We value your trust and work hard to provide the support and answers you deserve. With the largest, most experienced field sales and support team in the industry, Baldwin has your back.

AVAILABILITY

Quality and high performance are not enough. Baldwin delivers. With an extensive distribution network and an unmatched factory fill-rate, you can trust Baldwin has the filters you need, when and where you need them.



YOUR SINGLE, RELIABLE FILTER PARTNER

WHATEVER YOU'RE DRIVING

Wherever the road takes you, Baldwin keeps you moving forward. With our in-depth understanding of the heavy-duty trucking industry and a relentless focus on new, innovative filtration technologies, Baldwin delivers heavy-duty protection for the next generation of advanced diesel engines.

FREIGHTLINER CASCADIA DETROIT DIESEL DD13 AND DD15 ENGINES

BALDWIN	OE	DESCRIPTION
LUBE		
P7505	A4721800109, A4721800309	Lube Element
FUEL		
PF9804	A0000903651	Fuel/Water Separator Element
PF9908 KIT	A4720900451 (2008-18)	Fuel Filter Kit
PF9924 KIT	A0000904251 (2008-17)	Fuel Filter Kit
AIR		
PA4857	VCC-T-1000921-S (Fresh Air)	Cab Air Element
CA5790	P610260	Channel Flow Air
PA30165	VCC-T-1000906-J (Recirculation)	Foam Cab Air Element
OTHER		
P5092	A4722030255	Coolant Element without Chemicals
PE5272	A0001420289 (2010 Emissions)	Urea Diesel Exhaust Fluid Filter in Plastic Shell
PE17000	5303604	Diesel Exhaust Fluid Filter

KENWORTH T680 CUMMINS ISX AND ISX-G ENGINES

BALDWIN	OE	DESCRIPTION
LUBE		
BD7154	4331005	High Velocity Dual-Flow Lube Spin-on
BD7509	LF9031 (ISX)	High Velocity Dual-Flow Lube Spin-on
BD50000	4367100, LF14000NN	High Efficiency Dual-Flow Lube Spin-on
FUEL		
[2] BF7695	3607140 (ISX-G)	Resin Ribbon Fuel Coalescer Spin-on with Drain
PF7930	FS19765 (ISX)	Fuel/Water Separator Element
BF9860	FF5686 (ISX)	Fuel Spin-on
BF9885	FF5776 (ISX)	Fuel Spin-on
PF9928	K371004 (ISX)	Fuel/Water Separator Element
BF46129	FF5825NN	Fuel Spin-on
AIR		
PA30093	X1987001	Cab Air Element
PA32000	P621725	EnduraCube Air Element
OTHER		
B5087	WF2127	Coolant Spin-on without Chemicals
CV15000	CV50634 (ISX)	Crankcase Breather
PE17000	5303604	Diesel Exhaust Fluid Filter

PETERBILT 579 PACCAR MX AND MX-13 ENGINES

BALDWIN	OE	DESCRIPTION
LUBE		
BC7326	1643072 (MX)	Centrifugal Lube Element
P40019	1643070	Full-Flow Lube Element
FUEL		
PF7930	FS19765	Fuel/Water Separator Element
BF9927	1655115 (MX)	High Efficiency Fuel Spin-on
PF9928	K37-1004 (MX-13)	Fuel/Water Separator Element
PF9929	K37-1009 (MX-13)	Fuel/Water Separator Element
AIR		
PA30107	W2084001	Foam Cab Air Element
PA30093	X1987001	Cab Air Element
PA32000	P621725	EnduraCube Air Element
OTHER		
B5088	1843659	Coolant Spin-on without Chemicals
PE17000	5303604	Diesel Exhaust Fluid Filter

VOLVO VNL SERIES VOLVO D13 ENGINES

BALDWIN	OE	DESCRIPTION
LUBE		
[2] B76-SS	4787362	Severe Service Lube Spin-on
B7685	477556-5	By-Pass Lube Spin-on
FUEL		
BF1366-O	20514654	Fuel/Water Separator Spin-on with Open Port for Bowl
PF7930	21737499, 85120233	Fuel/Water Separator Element
PF7744	FF5369	Fuel/Water Separator Element
BF7814	20430751, 20405160	Fuel Spin-on
AIR		
RS4642	20411815	Radial Seal Outer Air Element
RS4643	20411816	Radial Seal Inner Air Element
PA4681	20435801	Cab Air Element
OTHER		
B5145	20458771	Coolant Spin-on without Chemicals
PE17000	5303604	Diesel Exhaust Fluid Filter

MACK CXU613 MACK MP7 AND MP8 ENGINES

BALDWIN	OE	DESCRIPTION
LUBE		
[2] B76	20539275, 21707136	Full-Flow Lube Spin-on
BC7242	20552379	Centrifugal By-Pass Lube Element
B7409	20843764, 21707135	By-Pass Lube Spin-on
FUEL		
BF1386-O	20863191, 21017305, 21380521	Fuel/Water Separator Spin-on with Open Port for Bowl
BF7814	20539582	Fuel Spin-on
PF7930	Davco 382; FS19765	Fuel/Water Separator Element
BF7943	20972295	Fuel Spin-on
PF7680	301-SD-19B, 301-SD-19C	Fuel/Water Separator Element
AIR		
RS4634	57MD320M, 25100042	Radial Seal Air Element
RS4634XP	57MD320M, 25100042	Extreme Performance Nano Radial Seal Air Element
OTHER		
B5091	20575545	Coolant Spin-on without Chemicals
BW5183	21937331, 20539991	Coolant Spin-on with BTE Formula
PE17000	5303604	Diesel Exhaust Fluid Filter

DEPENDABILITY FOR THE LONG HAUL
IT'S IN OUR BLOOD

COVERAGE TO GET YOU WHERE YOU'RE GOING

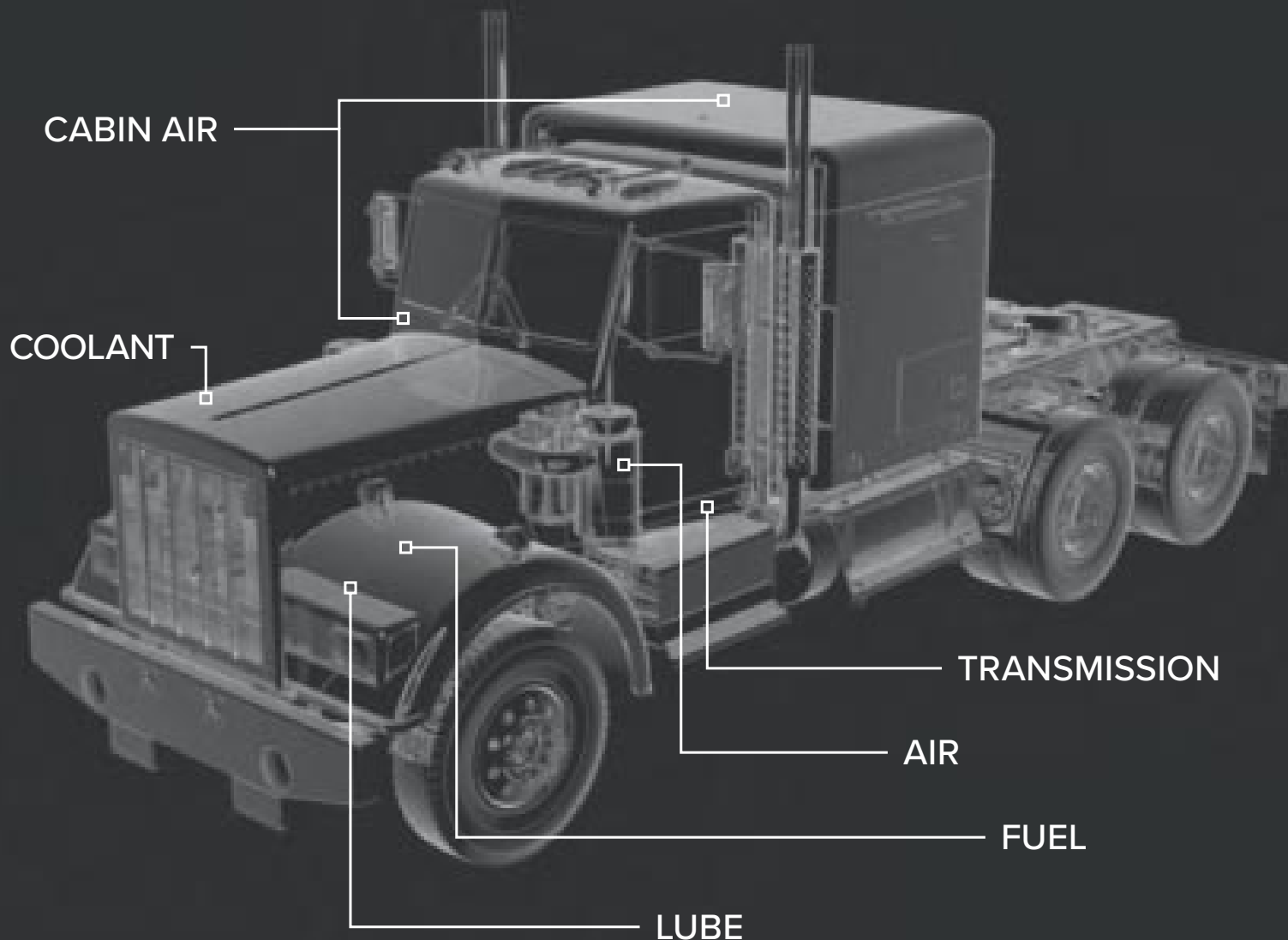

Your truck is your livelihood – no matter what you drive, you can be sure Baldwin has the protection long drives demand. With an extensive line of quality filtration products for all types of diesel trucks, we've got the coverage to be your single, reliable partner for all of your filtration needs.

PERFORMANCE TO KEEP YOU MOVING FORWARD

NEXT GENERATION

AIR

Baldwin air filters are as tough as they are efficient, ensuring uncompromised performance over the entire life of the filter. Advanced media and durable designs protect your equipment under the harshest conditions.

ENDURACUBE™

ADVANCE TECHNOLOGY
IN AIR FILTRATION



CA32000

Baldwin's EnduraCube air filters, with new depth-loading media technology, deliver outstanding performance in a revolutionary, new patent-pending design.

- **High capacity in an innovative, compact design**
- **Exceptional efficiency to keep your engine running smoothly**
- **Withstands vibration, pressure and temperature variations to deliver superior protection for the entire service interval**

Baldwin filters are vigorously tested above and beyond industry standards, ensuring reliable performance under the toughest conditions.

QUALITY TRUSTED FOR GENERATIONS

MAXIMUM CAPACITY LUBE

Longer drain intervals require filters that have both high capacity and the ability to withstand the rigors of time and temperature without failing. Baldwin's lube filters are up to the challenge.

BD50000

■ BALDWIN ■ COMPETITOR

CAPACITY (g)

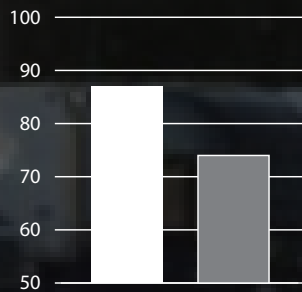

EFFICIENCY (%)

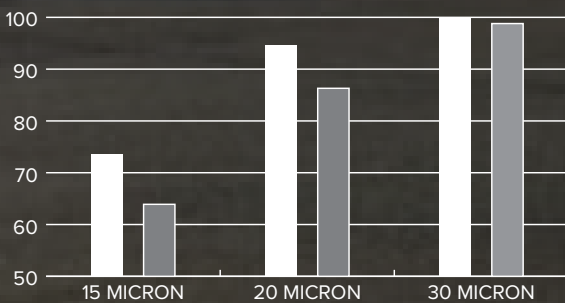

ISO 4548-12 Test: Flow Rate 28 gpm, ISO Medium Test Dust, Termination at 25 psid

For Cummins® 2010-16 ISX15 and 2017-on X15 Engines

OPTIMAL EFFICIENCY FUEL

Baldwin fuel filters use sophisticated new technologies to keep fuel pristinely clean of even the smallest contaminants and enable precision, high pressure fuel systems to operate at maximum efficiency.

PF9928

■ BALDWIN ■ COMPETITOR

CAPACITY (g)

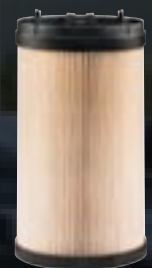
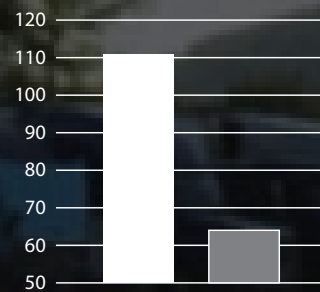

EFFICIENCY (%)

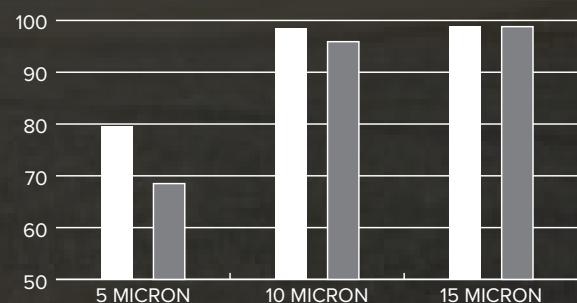

ISO 19438 Test: Flow Rate 2 gpm, ISO Medium Test Dust, 104°F, Termination at 4 psid

For Cummins® ISL, ISX and Paccar® MX, MX-13 Engines



800.822.5394 | baldwinfilters.com

Designed and manufactured in the USA.

Form 607 (R 10/19) © 2019 Baldwin Filters, a Parker Hannifin Company

WARNING: These products can expose you to chemicals, including Diisononyl Phthalate, Carbon black extracts, Nickel, 1,3 Butadiene, Ethylene Oxide, Epichlorohydrin, which are known to the State of California to cause cancer, and Bisphenol-A, Ethylene Glycol, Ethylene Oxide, 1,3 Butadiene, Epichlorohydrin, which are known to the State of California to cause birth defects or other reproductive harm. For more information go to www.P65Warnings.ca.gov.



CONSTRUCTION FILTRATION

RUGGED PERFORMANCE
IT'S IN OUR BLOOD



YOU'RE ONLY AS GOOD AS THE COMPANY YOU KEEP

You mean what you say and you expect the same from others. When we talk about our quality, performance, reliability and durability, we stand behind our words with an ironclad warranty. Whatever the tough challenges you face every day, with Baldwin, filtration won't be one of them. Baldwin has what it takes to be your one-source filter provider to keep your equipment running and your job on schedule.

QUALITY

When it comes to protecting your engine, you don't settle for anything but the best. Neither does Baldwin. Every phase of production, from raw material purchase to final inspection, is designed to ensure the highest quality and performance standards.

SERVICE

Getting an honest answer is important to you. Baldwin agrees. We value your trust and work hard to provide the support and answers you deserve. With the largest, most experienced field sales and support team in the industry, Baldwin has your back.

AVAILABILITY

Quality and high performance are not enough. Baldwin delivers. With an extensive distribution network and an unmatched factory fill-rate, you can trust Baldwin has the filters you need, when and where you need them.



YOUR SINGLE, RELIABLE FILTER PARTNER

WHATEVER THE CONDITIONS

No matter how hard the job or how tough the conditions, Baldwin will make sure you can get the job done on time. With an in depth understanding of the heavy-duty construction industry and a relentless focus on innovative filtration technologies, Baldwin has a full range of filters to keep all major equipment brands running at peak performance.

BOBCAT

BALDWIN	OE	DESCRIPTION
AIR		
RS3542	6666375	Radial Seal Outer Air Element
RS3704	6672467	Radial Seal Outer Air Element
RS3715	6673752, 54477187	Radial Seal Outer Air Element
PA31010	7286652	Primary EnduraPanel Air Element
PA31013	7221933, 7286322	Primary EnduraPanel Air Element
FUEL		
BF788	1992367	Secondary Fuel Spin-on
BF988	5411656493	Fuel Spin-on
BF1226	3903202	Fuel/Water Separator Spin-on with Drain
BF1280	1992366	Fuel/Water Separator Spin-on with Drain
BF7674-D	6670996	Secondary Fuel/Water Separator Element with Drain
LUBE		
BT223	6513601, 6652366	Full-Flow Lube Spin-on
BT237	2654407, 960698	Full-Flow Lube Spin-on
B7125	RE59754	Full-Flow Lube Spin-on
B40070	7012303	Lube Spin-on
HYDRAULIC		
BT8851-MPG	6668819	Maximum Performance Glass Hydraulic Spin-on
BT8874-MPG	6670207	Maximum Performance Glass Hydraulic Spin-on

CAT

BALDWIN	OE	DESCRIPTION
AIR		
RS3542	2310167, 1547108	Radial Seal Outer Air Element
RS3544	1106326, 1318902	Radial Seal Outer Air Element
RS3715	1394834	Radial Seal Outer Air Element
RS3744	1421339	Radial Seal Outer Air Element
FUEL		
BF7587	1R0749	Fuel Spin-on
BF7674-D	1005593, 1383098, 1596102	Secondary Fuel/Water Separator Element with Drain
PF46049	3635819	Fuel/Water Separator Element
LUBE		
B76	492164004	Full-Flow Lube Spin-on
B99	2721788, 1R0716, 2P4005	Full-Flow Lube Spin-on
B7299	2752604, 1R1808	High Efficiency Lube Spin-on
B7577	9Y4468, 3304232	By-Pass Lube Spin-on
B7600	1R0658, 1R0739, 1W3300, 2P4004, 2Y8096	Full-Flow Lube Spin-on
HYDRAULIC		
BT287-10	4T6788, 8J1600, 9T5664	Hydraulic Spin-on

For complete engine filter listing visit baldwinfilters.com

JOHN DEERE

BALDWIN	OE	DESCRIPTION
AIR		
RS3542	4684349, AP33330, KV16428	Radial Seal Outer Air Element
RS3544	4486002, KV16429, AT171853, AT262566	Radial Seal Outer Air Element
PA30207	RE282286	Conical-Shaped Outer Air Element
FUEL		
BF1212	1132400441, PMFS1212	Fuel/Water Separator Spin-on with Drain
BF1259	FS1000	Fuel/Water Separator Spin-on with Drain
BF1293-SPS	FS1003	Fuel/Water Separator Spin-on with Drain, Sensor Port and Reusable Sensor
BF7929 KIT	RE525523, RE541746	Set of 2 Fuel Filters
BF7674-D	RE60021	Secondary Fuel/Water Separator Element with Drain
LUBE		
BD103	LF3000, RE44647	Dual-Flow Lube Spin-on
BD7309	AT193242	High Velocity Dual-Flow Lube Spin-on
B7322	RE504836, RE507522, RE541420	Lube Spin-on
HYDRAULIC		
BT8851-MPG	T175002	Maximum Performance Glass Hydraulic Spin-on
BT8874-MPG	AT112393	Maximum Performance Glass Hydraulic Spin-on

KOMATSU

BALDWIN	OE	DESCRIPTION
AIR		
RS3517	6001854100, 6001854110	Radial Seal Outer Air Element
RS3542	12993512520, 21W01R9250, 22E0211011, 42U01H0P02, 6001852210, 848101146, YM12993512520	Radial Seal Outer Air Element
RS3544	848101144, 848101189, 2260211111, 42N0211960, 42R01H0P06, 6001852100, 6001852110, P828889	Radial Seal Outer Air Element
RS3704	11980812520, 12961912520, YM11980812520	Radial Seal Outer Air Element
FUEL		
BF1212	1240483H1, 1214920H1	Fuel/Water Separator Spin-on
BF1226	1240619H2, 6732716310, 6733719110	Fuel/Water Separator Spin-on
BF1262	6003117550, 6003193111, 6003113110, 6003113111, 76999473, BF4803, FS1006	Fuel/Water Separator Spin-on
BF46002	2441458	High Efficiency Fuel Spin-on
LUBE		
B96	6002111230, 6002111231, 6002111291, LF670, LF747	Full-Flow Lube Spin-on
BD103	1294153H1, 1295224H1, 3318853, 6742012430, 6742014120	Dual-Flow Lube Spin-on
BD7176	BF5209, LF9024, LF9050	High Velocity Dual-Flow Lube Spin-on
B7177	21U6011320, 21U6011330, T3937736	Lube Spin-on
BD7309	6742014540	High Velocity Dual-Flow Lube Spin-on
HYDRAULIC		
BT839-10	PB5556	Hydraulic Spin-on
BT8850-MPG	1281327H1	Maximum Performance Glass Hydraulic Spin-on

**RUGGED PERFORMANCE
IT'S IN OUR BLOOD**

COVERAGE WHEN THERE'S NO TIME TO WASTE

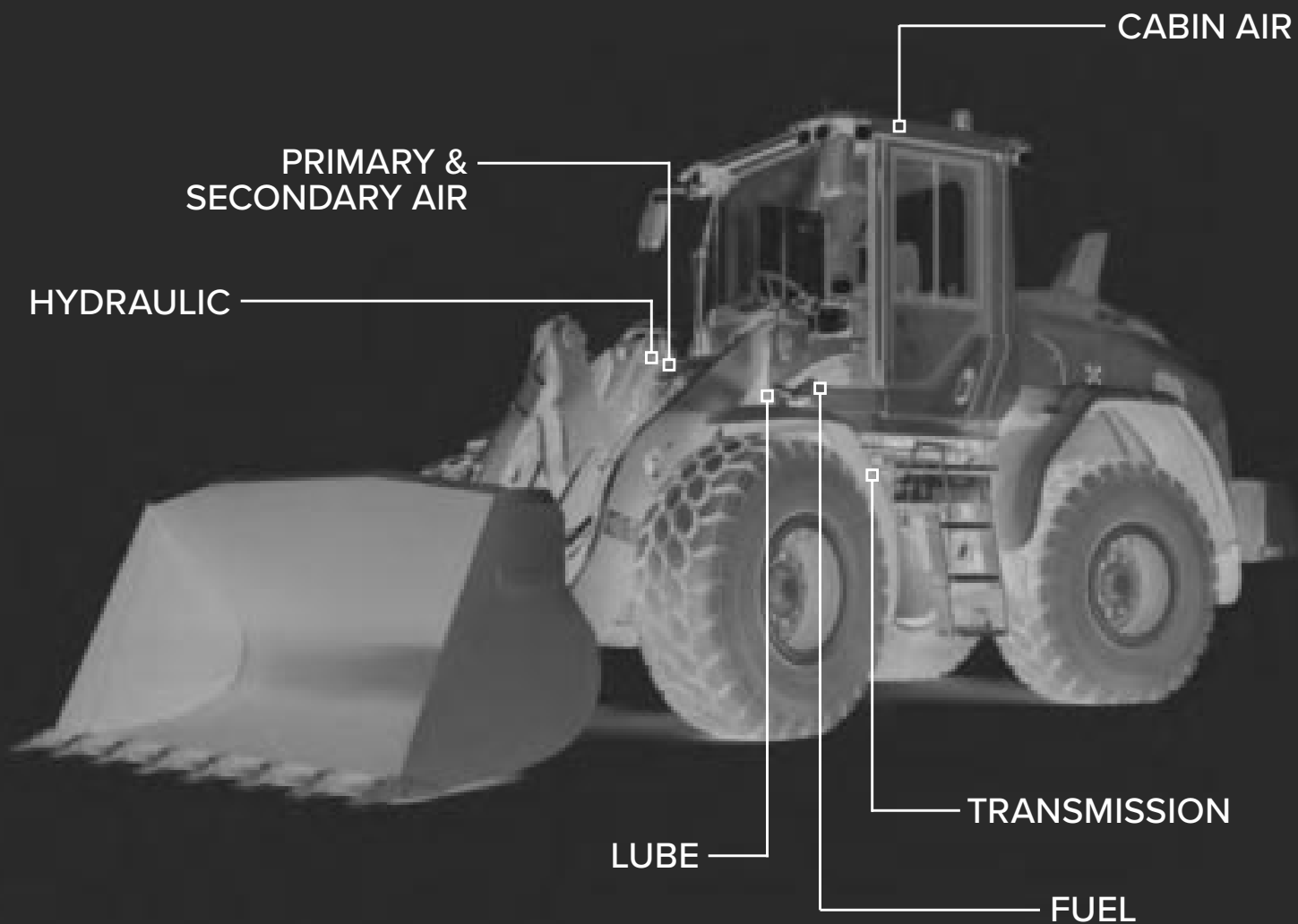

The days are long but the season is short. When time is of the essence, you need a go-to source for all of your filtration needs. With an extensive line of quality filtration products for all types of heavy-duty equipment, Baldwin is your single, reliable filtration partner.

PERFORMANCE IN THE TOUGHEST CONDITIONS

STRUCTURALLY SUPERIOR AIR

Baldwin filters are as tough as they are efficient. Advanced media technology and rugged, durable design ensures uncompromised efficiency over the entire life of the filter, delivering outstanding protection for your equipment under the harshest conditions.

PA31010

■ BALDWIN ■ COMPETITOR

CAPACITY (g)

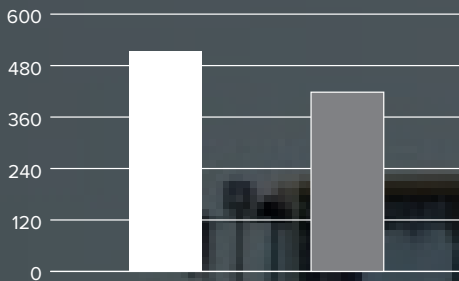

EFFICIENCY (%)

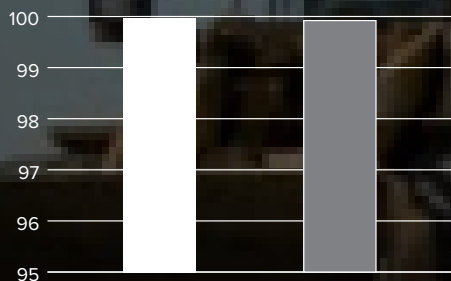

ISO 5011 Test: Flow Rate 250 SCFM, ISO Fine Test Dust,
Termination at 30" of Water

For Bobcat Loaders



Baldwin filters are vigorously tested above and beyond industry standards, ensuring reliable performance in the toughest conditions.

QUALITY TRUSTED FOR GENERATIONS

MAXIMUM CAPACITY LUBE

Longer drain intervals require filters that have both high capacity and the ability to withstand the rigors of time and temperature without failing. Baldwin's lube filters are up to the challenge.

BD7309

■ BALDWIN □ COMPETITOR

CAPACITY (g)

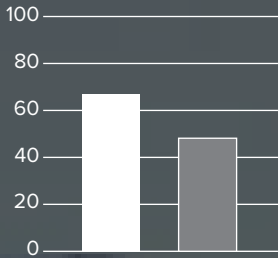

EFFICIENCY (%)

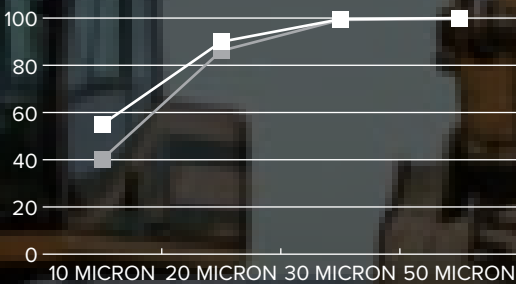

ISO 4548-12 Test: Flow Rate 28 gpm, ISO Medium Test Dust, Termination at 25 psid

For John Deere Excavators and Komatsu Crawler Carriers, Dozers, Excavators, Graders and Loaders

OPTIMAL EFFICIENCY FUEL

Baldwin fuel filters use sophisticated new technologies to keep fuel pristinely clean of even the smallest contaminants and enable precision, high pressure fuel systems to operate at maximum efficiency.

BF46002

■ BALDWIN □ COMPETITOR

CAPACITY (g)

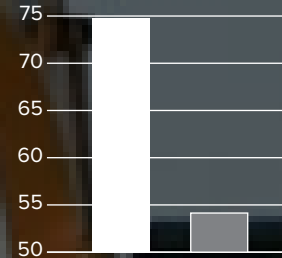

EFFICIENCY (%)

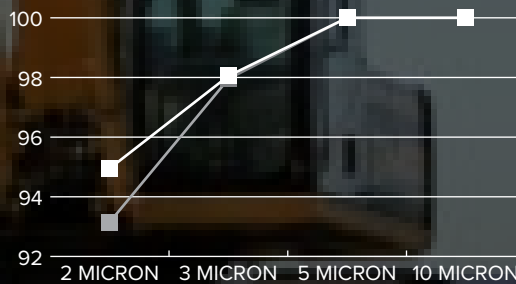

ISO 19438 Test: Flow Rate 3 gpm, ISO Medium Test Dust, 104°F, Termination at 5 psid

For Komatsu Dump Trucks and Hitachi Dump Trucks, Excavators and Loaders



800.822.5394 | baldwinfilters.com

Designed and manufactured in the USA.

Form 622 (R 11/19) © 2019 Baldwin Filters, a Parker Hannifin Company

WARNING: These products can expose you to chemicals, including Diisononyl Phthalate, Carbon black extracts, Nickel, 1,3 Butadiene, Ethylene Oxide, Epichlorohydrin, which are known to the State of California to cause cancer, and Bisphenol-A, Ethylene Glycol, Ethylene Oxide, 1,3 Butadiene, Epichlorohydrin, which are known to the State of California to cause birth defects or other reproductive harm. For more information go to www.P65Warnings.ca.gov.



AGRICULTURE FILTRATION

HARD WORK
IT'S IN OUR BLOOD

WERE YOU BORN IN A BARN?

Maybe not, but farming is in your blood. You work hard every day. It's a tough life, with plenty to worry about. You shouldn't have to worry about filtration. Let Baldwin make it easier. Baldwin has been around for generations. We have the coverage, quality, service and dependability you need. Whether you're in the fields 24/7 or hauling valuable cargo, Baldwin has what it takes to be your one-source filter provider and keep your trucks and equipment running when you need them.



QUALITY

When it comes to protecting your equipment, you don't settle for anything but the best. Neither does Baldwin. Every phase of production, from raw material purchase to final inspection, is designed to ensure the highest quality and performance standards.

SERVICE

Getting an honest answer is important to you. Baldwin agrees. We value your trust and work hard to provide the support and answers you deserve. With the largest, most experienced field sales and support team in the industry, Baldwin has your back.

AVAILABILITY

Quality and high performance are not enough. Baldwin delivers. With an extensive distribution network and an unmatched factory fill-rate, you can trust Baldwin has the filters you need, when and where you need them.



YOUR SINGLE, RELIABLE FILTER PARTNER

WHATEVER YOU'RE OPERATING

It's not just a job, it's a way of life. You count on your equipment for your livelihood. You need a filter you can trust. With a history deeply connected to farming, Baldwin has an in-depth understanding of the ag industry and a relentless focus on new, innovative filtration technologies to deliver heavy-duty protection for generations to come.

CASE-INTERNATIONAL AXIAL FLOW COMBINES

5140, 6140, 7140 w/FPT 8.7L ENG

BALDWIN	OE	DESCRIPTION
LUBE		
B7174-MPG	84346773	Maximum Performance Glass Lube Spin-on
B7327	84228488	Lube Spin-on
FUEL		
BF1365	84348882	Fuel/Water Separator Element
BF7696	84597064	Fuel Spin-on
BF7912	84477370	Box-Style Fuel Element
BF7922	84412164	Fuel Spin-on
AIR		
PA5668	360260A2	Cab Air Element
RS3544	84217229	Radial Seal Outer Air Element
RS3926	86998333	Radial Seal Outer Air Element
RS3927	86998332	Radial Seal Inner Air Element
HYDRAULIC		
BT8308-MPG	1329214C1, A177605	Maximum Performance Glass Hydraulic Spin-on

JOHN DEERE HILLMASTER COMBINES

S650 STS, S660 STS, S670, S670 STS w/POWERTECH PSX 9.0L ENG

BALDWIN	OE	DESCRIPTION
LUBE		
P7233	RE509672	Lube Element
AIR		
PA5696	RE284091	Cab Air Element
RS30009	HXE11091	Radial Seal Inner Air Element
RS30008	HXE11090	Radial Seal Outer Air Element
PA30117	L155288	Set of 2 Cab Air Elements
FUEL		
BF7929 KIT	RE525523	Set of 2 Fuel Filters
BF9866-O	RE539465	Fuel/Water Separator Spin-on
BF9917	RE533910	High Efficiency Fuel Spin-on
HYDRAULIC		
BT8852-MPG	AH128449	Maximum Performance Glass Hydraulic Element
PT9414-MPG (S670, S670 STS only)	AN207368	Maximum Performance Glass Hydraulic Element

JOHN DEERE TRACTORS

8285R, 8310R, 8360R w/POWERTECH PSX 9.0L ENG, 8295R, 8320R w/6090 POWERTECH PLUS ENG

BALDWIN	OE	DESCRIPTION
LUBE		
P7233	RE509672, RE538245	Lube Element
FUEL		
BF7929 KIT	RE525523	Set of 2 Fuel Filters
BF9866-O	RE539465	Fuel/Water Separator Spin-on with Open Port for Bowl
BF9917	RE533910	High Efficiency Fuel Spin-on
AIR		
PA5689	RE291412	Cab Air Element
PA5696	RE284091	Cab Air Element
RS5354	RE210102	Radial Seal Outer Air Element
RS5355	RE210103	Radial Seal Inner Air Element
HYDRAULIC		
BT8876-MPG	RE210857	Maximum Performance Glass Hydraulic Spin-on

MASSEY FERGUSON TRACTORS

7619, 7620, 7622, 7624 w/AGCO 66 CTA (6.6L) ENG (DYNA VT, DYNA STEP)

BALDWIN	OE	DESCRIPTION
LUBE		
B7179	V836662580	Lube Spin-on
FUEL		
BF1391-O	3905873M91	Fuel/Water Separator Spin-on with Open Port for Bowl
AIR		
CA5514	4286473M2	Channel Flow Pri. Air Element
PA5515	4286474M1	Channel Flow Sec. Air Element
PA5682	3786649M3	Cab Air Element
HYDRAULIC		
PT9395-MPG	72311028	Maximum Performance Glass Hydraulic Element
PT9530	72312070	Hydraulic Element

NEW HOLLAND COMBINES

CX5080, CX5090, CX8030, CX8040, CX8050, CX8060

BALDWIN	OE	DESCRIPTION
LUBE		
BT7237 (CX8030 only)	504074043	Lube Spin-on
BT7237 (CX5080, CX5090 only)	4897898	
FUEL		
BF7696 (CX8040, CX8050, CX8060 only)	504199551	Fuel Spin-on
BF7881	336430A1	Box-Style Fuel Filter
BF7966 (CX5080, CX5090, CX8030 only)	4897897	Fuel Spin-on
AIR		
RS3544 (Exc. CX5080, CX5090)	84036676, 87682993,	Radial Seal Outer Air Element
PA30126 (Exc. CX5080, CX5090)	84058793	Cab Air Element
RS30181	84072430	Inner Air Element
RS30182	84072431	Outer Air Element
HYDRAULIC		
BT8450 (CX5080, CX5090 only)	9814477	Hydraulic Spin-on
BT8850-MPG (Exc. CX5080, CX5090)	84074777	Maximum Performance Glass Hydraulic Spin-on
BT8851-MPG	81863799	Maximum Performance Glass Hydraulic Spin-on
BT8851-MPG (CX5090 only)	9821387	Maximum Performance Glass Hydraulic Spin-on

HARD WORK
IT'S IN OUR BLOOD

COVERAGE TO GET YOUR JOB DONE ON TIME

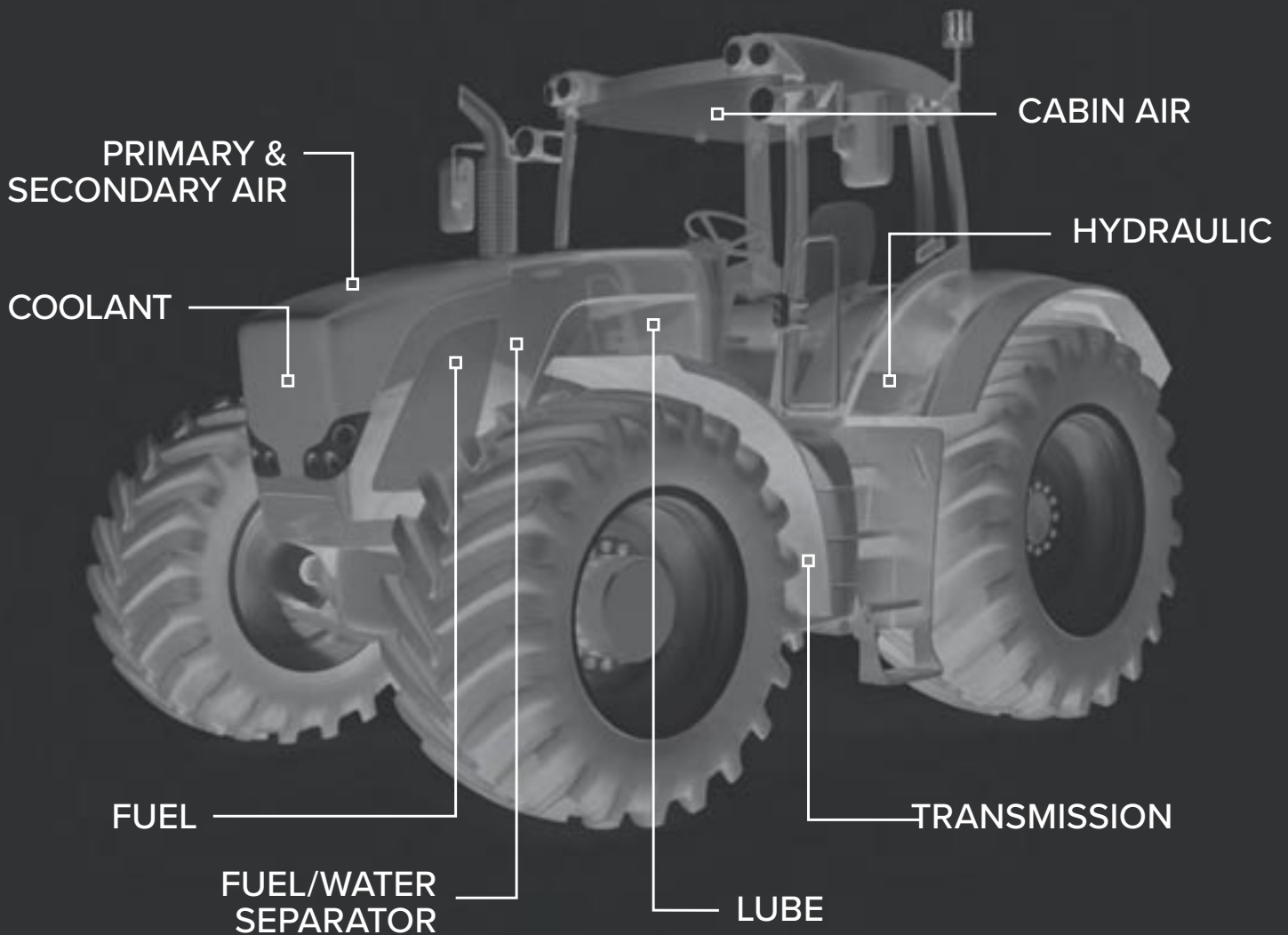

Your livelihood depends on your equipment – no matter what the job or what the conditions, you can be sure Baldwin has the protection tough jobs demand. With an extensive line of quality filtration products for all types of diesel trucks and equipment, we've got the coverage to be your single, reliable partner for all of your filtration needs.

PERFORMANCE TO KEEP YOU IN THE FIELDS

DURABLE PERFORMANCE

AIR

Baldwin air filters are as tough as they are efficient, ensuring uncompromised efficiency over the entire life of the filter. Durable designs protect your equipment under the harshest conditions.

RS30182

■ BALDWIN ■ OE

EFFICIENCY (%)

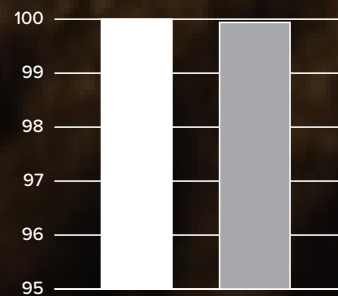

CAPACITY (g)

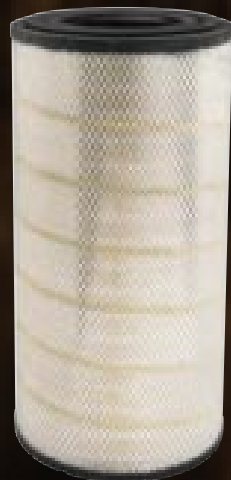
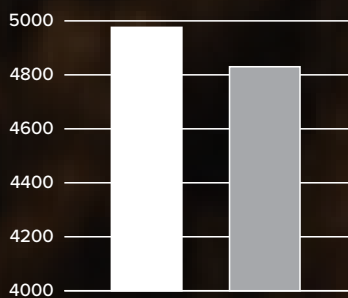

ISO 5011 Test: Flow Rate 1100 SCFM, ISO Fine Test Dust, Termination at 30" of water

For Fendt Combines; Massey Ferguson, New Holland Combines

Baldwin filters are vigorously tested above and beyond industry standards, ensuring reliable performance under the toughest conditions.

QUALITY TRUSTED FOR GENERATIONS

MAXIMUM CAPACITY LUBE

Baldwin lube filters are up to the challenge of providing both high capacity and the ability to withstand the rigors of time and temperature without losing efficiency.

B7174-MPG

■ BALDWIN ■ OE

CAPACITY (g)

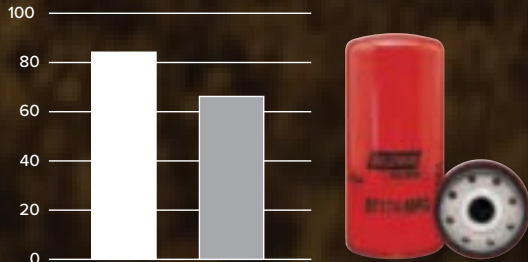

EFFICIENCY (%)

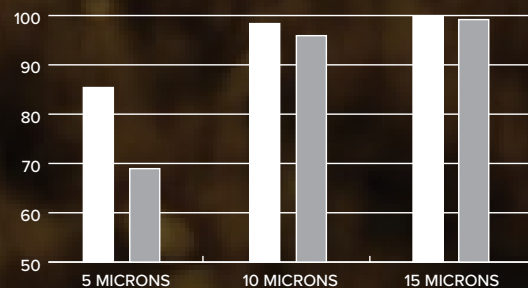

ISO 4548-12 Test: Flow Rate 20 gpm, ISO Medium Test Dust, 104°F, Termination at 20 psid

For Case-International, New Holland Combines, Tractors

OPTIMAL EFFICIENCY FUEL

Baldwin fuel filters keep fuel pristinely clean of even the smallest contaminants and enable precision, high pressure fuel systems to operate at maximum efficiency.

BF9917

■ BALDWIN ■ OE

CAPACITY (g)



EFFICIENCY (%)

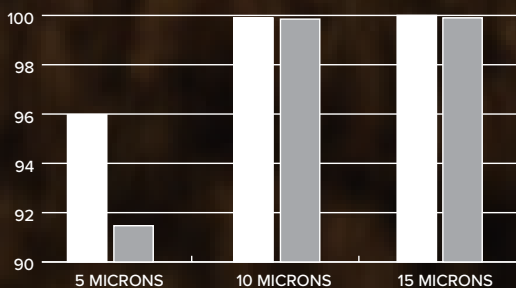

ISO 19438 Test: Flow Rate 3 gpm, ISO Medium Test Dust, 104°F, Termination at 5 psid

For John Deere Combines, Tractors and Sprayers



800.822.5394 | baldwinfilter.com

Designed and manufactured in the USA.

Form 620 (1/18) © 2018 Baldwin Filters, a Parker Hannifin Company



WARNING: These products can expose you to chemicals, including Diisononyl Phthalate, Carbon black extracts, Nickel, 1,3 Butadiene, Ethylene Oxide, Epichlorohydrin, which are known to the State of California to cause cancer, and Bisphenol-A, Ethylene Glycol, Ethylene Oxide, 1,3 Butadiene, Epichlorohydrin, which are known to the State of California to cause birth defects or other reproductive harm. For more information go to www.P65Warnings.ca.gov.



Red-L Distributors Ltd.

www.redl.com

1.800.252.9390

Bonnyville 780.826.2333
Bonnyville@redl.com

Edmonton west 780.451.2820
rednorth@redl.com

Fort McMurray 780.791.0404
ftmac@redl.com

Grande Prairie 780.814.6010
gp@redl.com

Nisku 780.437.2630
Sales@redl.com

Spruce Grove 780.962.1147
sprucegrove@redl.com

Calgary 403.720.2872
calgary@redl.com

Edmonton south 780.431.8643
redsouth@redl.com

Fort St. John 778.715.2909
fortstjohn@redl.com

Lloydminster 780.871.0766
Lloydminster@redl.com

Red Deer 403.346.4673
reddeer@redl.com

Whitecourt 780.778.5119
whitecourt@redl.com